



LOWE & FLETCHER

LOCKING SYSTEMS FOR INDUSTRY

**NO MORE
LOST KEYS**

Nimbus RFID Digital Combination Lock

The flexibility of our existing Nimbus digital keypad lock is now expanded to RFID contactless usage as well.

Right down to the printed circuit board, Lowe & Fletcher manufactures these locks in our own facility to exacting standards, including the use of encrypted RFID protocols.

The Nimbus range of locks are all designed to fit the same footprint as our standard electronic lock range, making them easy to upgrade or retro-fit to existing installations.

Available in wet area version, public, private and RAS remote allocation modes, typical applications for the lock include commercial and office environments, lockers and enclosures.



Product ID: 3964



Product ID: 3963

Nimbus RFID Digital Combination Lock

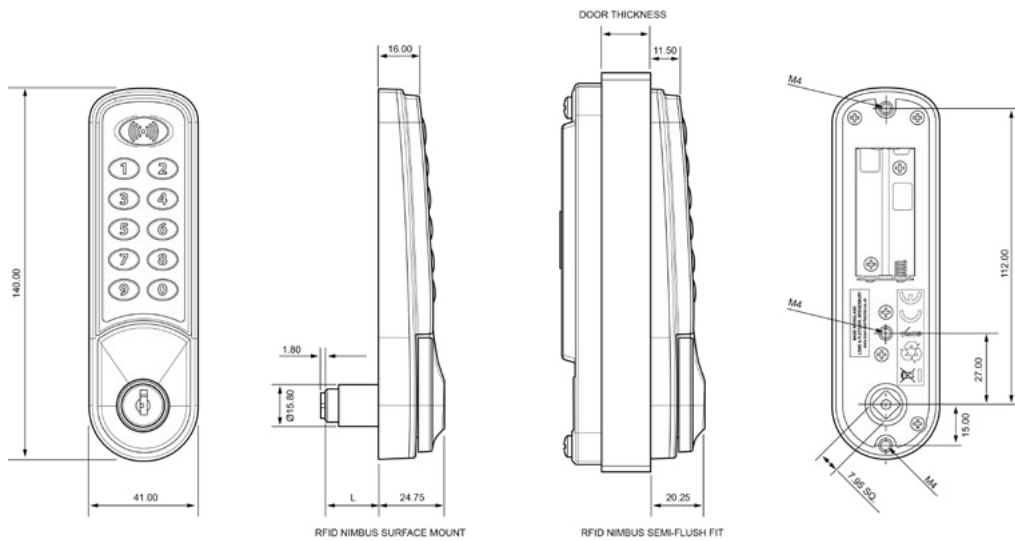

Product ID: 3963

Standard Features

- ✓ Choice of RFID card or keypad use
- ✓ Black, silver or white as standard
- ✓ Chrome and brushed nickel finishes available on request
- ✓ Surface mount and semi-flush fit mounting options (maximum 20mm protrusion)
- ✓ Steel override key
- ✓ Two or three-point installation
- ✓ Wide variety of cams
- ✓ LED indicator lights
- ✓ Optional audible keypad
- ✓ Battery condition indicator
- ✓ 8-digit master code
- ✓ 6-digit sub-master code
- ✓ 4 or 6-digit user code
- ✓ Private or public user modes
- ✓ Default 24mm spindle length
- ✓ Technician mode
- ✓ 2 x AAA batteries (included)
- ✓ Up to 50,000 cycles per pair of batteries
- ✓ Vertical, left and right hand keypads
- ✓ Multiple incorrect code timed lock-out protection
- ✓ High, normal or low speed detection mode

Programming Features

- ✓ Change master card
- ✓ Add user card (private mode only)
- ✓ Set private mode
- ✓ Set public mode
- ✓ Set audio

Optional Features

- ✓ Available with Remote Allocation System (RAS)
- ✓ One or two time RAS mode
- ✓ Alternative colors
- ✓ Pre-programmed modes and codes
- ✓ Customized logo



Low & Fletcher Inc (USA)
 E: sales@loweandfletcherinc.com
 T: +1 (616) 994 0490
 W: www.loweandfletcherinc.com