

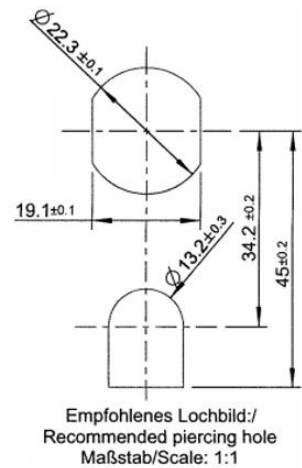

LOWE & FLETCHER

LOCKING SYSTEMS FOR INDUSTRY

Technical Information

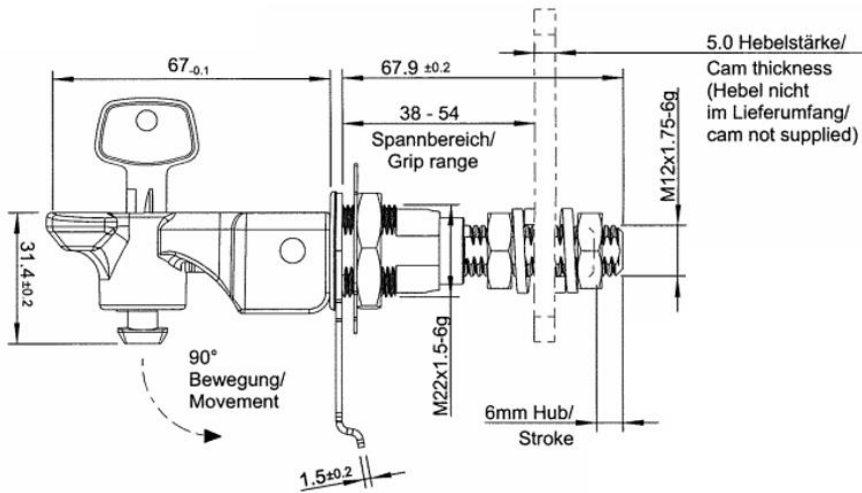

Heavy Duty Lift & Turn Compression Latch

Standard features:

- Standard mounting holes
- Material thickness: 0.6 - 10 mm
- Vibration-proof mounting
- 200 Standard key codes
- Dust and particle protected locking cylinder
- Stainless steel cam available in various designs
- Custom locking systems and finishes available on request

Lowe & Fletcher, Inc.
650 Airport Place
Norton Shores MI-49441

T: +1 (616) 994 0490
F: +1 (616) 994 0480

E: sales@loweandfletcherinc.com
W: www.loweandfletcherinc.com