

Installation Template

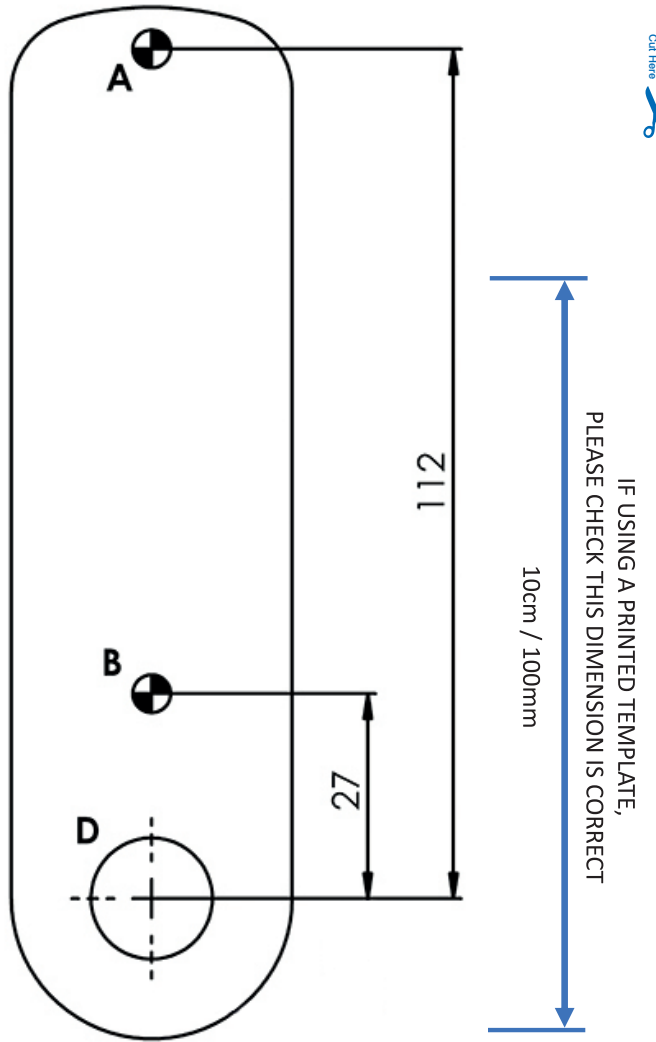

HOLES A, B & C DIAMETER 4.5 / 5.0mm
HOLE D DIAMETER 16.5 / 17mm
ALWAYS USE FIXING HOLE A and B

IMPORTANT NOTE

Before drilling fixing holes, please ensure that the position of the Digital Combination Lock when fitted will allow clearance for the cam to function.

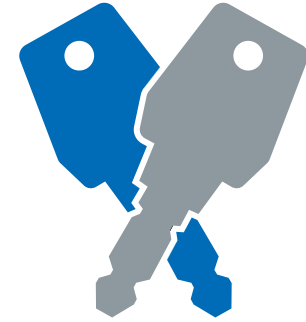

INSTALLATION INSTRUCTIONS

2383 Slam Module Digital Combination Locks

Lowe & Fletcher Inc
650 Airport Place
Norton Shores MI-49441

T: +1 (616) 994 0490
F: +1 (616) 994 0480
E: sales@loweandfletcherinc.com
W: www.loweandfletcherinc.com

L&F A Lowe & Fletcher Group Company

9226565 - 2383 Slam Module Instructions V1 October 2020

loweandfletcherinc.com

INSTALLATION INSTRUCTIONS

2383 - Slam Module For Digital Combination Lock

FITTING INSTRUCTIONS

The Digital Combination Lock Slam Module can be fitted to cupboards, cabinets and lockers etc.

SPECIAL NOTES

Before installing the Digital Combination Lock,

Master Code is 11 33 55 77 and the default **User Code is 22 44**.

These codes are common to all standard locks and it is very important that you set your own personal Master and User Codes. Your lock is not secure until you have changed the default Master Code and User Code. Keep a safe record of your master code as it is not possible to make any programming changes without it.

Please see programming guide to set your own codes.

INSTALLATION GUIDE - IMPORTANT NOTES

The 2383 slam module lock is to be fitted with two screws. Always use the screw position "A" and "B".

Ensure 3-8mm of screw thread engagement when fitting to the DCL.

Check the correct slam lock is supplied for the application.

Short drive 2383/0/ for panels 0.8-17mm

Long drive 2383/1/ for panels 18-30mm

ENSURE BATTERY IS FITTED BEFORE FIXING TO CLOSURE

A) New Installation

- Step 1** Place template on door and mark TWO $\varnothing 4.5\text{mm}$ (3/16") holes (refer to installation diagrams). Use hole position "A" and "B". Mark ONE $\varnothing 17\text{mm}$ hole.
- Step 2** Drill the two $\varnothing 4.5\text{mm}$ fixing holes and the $\varnothing 17\text{mm}$ clearance hole.
- Step 3** Fit the Digital Combination Lock to the door by passing the spindle through the $\varnothing 17\text{mm}$ hole.
- Step 4** Place the Slam module on the inside of the panel aligning up the square drive and the fixing holes.
- Step 5** Using the M4 screws fix the slam module to the panel using the tapped holes in the DCL.
- Step 6** Check the operation of the lock using the factory User Code 22 44.
- Step 7** If the lock is functioning correctly, CHANGE THE DEFAULT MASTER CODE 11 33 55 77 and DEFAULT USER CODE 22 44 and program the lock using the programming and operating instructions enclosed.

IMPORTANT NOTE

Please ensure 3-8mm of thread engagement when fixing the screws Digital Combination Lock

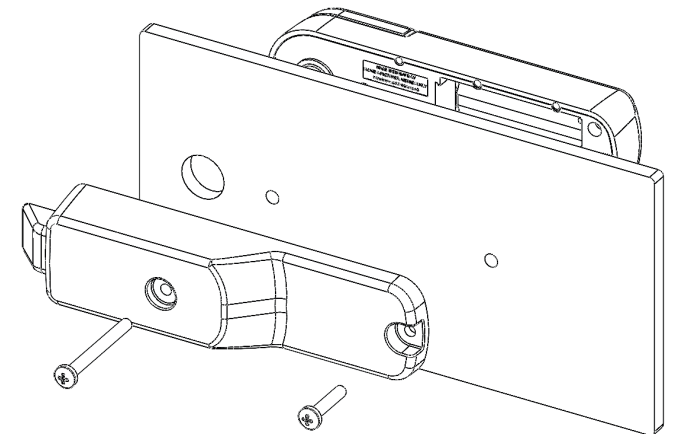
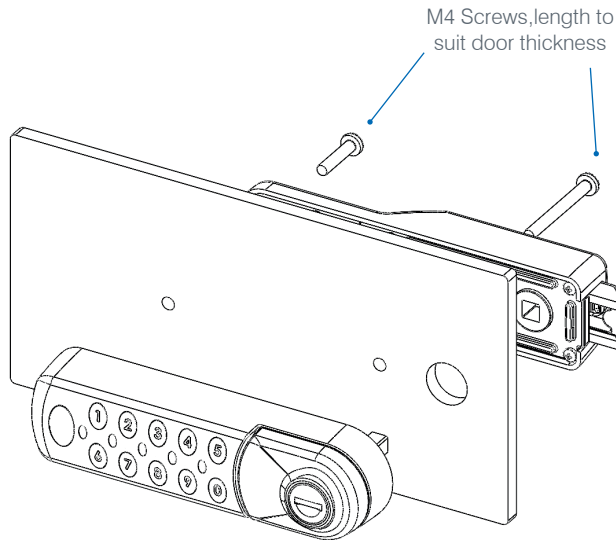

HOLES A & B DIAMETER 4.5 / 5.0mm
HOLE D DIAMETER 16.5 / 17mm
ALWAYS USE FIXING HOLE A AND HOLE B
Recommended screw fixing torque 0.8Nm